

Brookland Transportation and Streetscape Study

Meeting Minutes
June 14, 2006 (6:00-8:00 PM)
Reeves Center (DDOT)
2000 14th Street, NW
Washington DC 20009

■ Streetscape TAC Meeting

Location: DC Department of Transportation
Reeves Center, Large Conference Room, 6th Floor
2000 14th Street, NW
Washington DC 20009

■ Attendees

Sharlene Reed	DDOT	202.671.2407	Sharlene.Reed@dc.gov
Ken Laden	DDOT	202.671.2309	Ken.Laden@dc.gov
Oliver Boehm	Baker	703.960.4400	Oboehm@mbakercorp.com
Bettina Irps	Baker	703.960.4400	birps@mbakercorp.com
William Carlson	Volkert	703.642.8100	Wcarlson@volkert.com
John McGaw	Mayor's Office, <i>restoreDC/</i> DC Main Streets	202.478.1321	John.mcgaw@dc.gov
Leroy Hall	Resident	202.536.0183	lema@rcn.com
Tomika Hughey	Business Owner –12th Street Merchants Association	202.962.2429	thughey@wmata.com
Robert Barnard	HSC Pediatric Center	202.635.6186	rbarnard@hospsc.org
Edward M. Johnson	Brookland CDC/ Main Street	202.526.3610	ejohnson@emjohn.com
Lavinia Wohlfarth	Brookland CDC	202.529.8400	laviniawohlfarth@aol.com
Richard Houghton	Resident	202.526.7380	Mrac.brookland@verizon.net
Jeff Wilson	Greater Brookland Garden Club	202.526.6887	Jeffrey-Wilson@apsva.us
Enid A. Jackson	Com 5A09	202.529.7724	

■ Meeting Agenda

1. Welcome Sharlene Reed (DDOT)
2. Introduction & Opening Remarks Bill Carlson (Volkert)
 - Overview of Study
 - Focus of Tonight's Presentation
 - Next Presentation (Recommended Transportation Improvements)
3. Public Realm Recommendations (PowerPoint presentation) Oliver Boehm (Baker)
Bettina Irps (Baker)
4. Open Discussions ALL
 - Gateways
 - Roadway Bridges
 - Lighting & Utility Wires

Brookland Transportation and Streetscape Study

Meeting Minutes
June 14, 2006 (6:00-8:00 PM)
Reeves Center (DDOT)
2000 14th Street, NW
Washington DC 20009

- Sidewalks
- Street Furniture
- Street Trees

5. Overall Project Schedule

Bill Carlson (Volkert)

6. Next Steps & Closing Remarks

Sharlene Reed (DDOT)

■ Comments and Discussions:

The Draft Public Realm Report, subject of discussion for this meeting, was released and posted on the website on June 7, 2006. Hard copies were delivered to attendees on June 16, 2006. The PowerPoint presentation represented an excerpt of the report, focusing on the public realm recommendations. The following comments were noted during the meeting and discussions between the TAC attendees, consultants and DDOT representatives:

Focus:

- Sustainability; apply sustainable techniques throughout the study area.
- Increase lighting, especially sidewalk illumination, to promote pedestrian safety and fight crime.
- Signage (graphics, wayfinding, history & educational) and art at gateways, including Newton Street.
- Tree selection: Follow UFA's approach 'the right tree for the right location'.
- Clarify the theme for 12th Street and its elements.

Concerns:

- Crime
- Maintenance
- Water supply for garden area at Northern gateway, explore options with existing nearby hydrant.
- The use of bulb-outs needs to be examined in the transportation part of the report. Not recommended for the 12th Street and Rhode Island Avenue intersection.
- Lighting/utility wires: what are short- and long-term options:

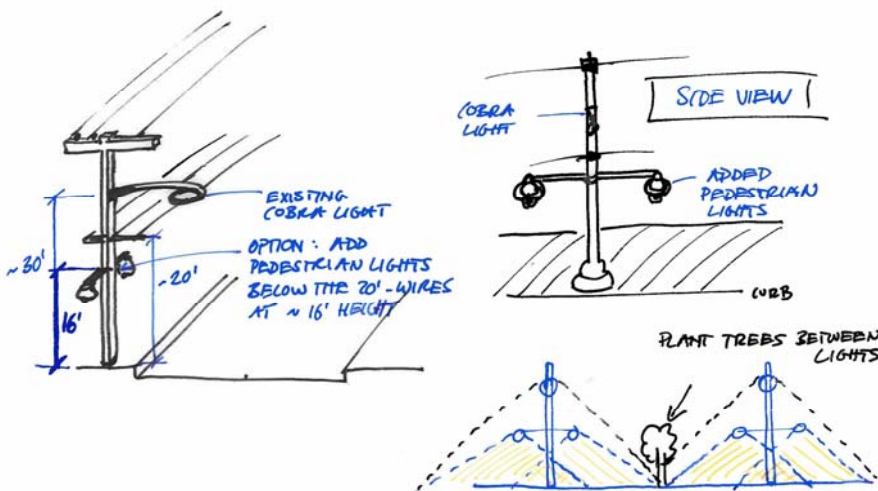

Brookland Transportation and Streetscape Study

Meeting Minutes
June 14, 2006 (6:00-8:00 PM)
Reeves Center (DDOT)
2000 14th Street, NW
Washington DC 20009

Ideas:

- Turn Newton Street between 12th Street and the Brookland Metro Station into an **Eastbound** one-way street to create a 'pedestrian walkway'. Recognize natural pedestrian paths.
- Set Main Street core apart with different trees, lights, and signage (shape, height, dimensions, material). Make use of the strong architectural features of the 35/3600 block of 12th Street.
- Brick on sidewalk edge rather than a brick gutter; brick gutter might accumulate debris and slow down the stormwater flow.
- Northern gateway: not a gathering place, enhance with entrance markers and art and provide for better pedestrian safety.
- Tree boxes/planting beds/ public right-of-way landscape strip: Tree planting should be coordinated with parking meters to prevent interference of planting areas and people exiting their cars. Residents are encouraged to take ownership of the landscaping and maintenance. Once landscaping is established, people are less likely to walk over it.
- Median on Monroe Street vs. bike and parking lanes.
- Different approach: Instead of emphasizing the existing high commercial density (Main Street 'core'), encourage development based on anticipated developments or development needs (e.g. at the Southern end of the 12th Street study area).

Requests:

- Provide a fully conceptualized site design (in plan and/or section); use mapping of existing conditions, curbing, sidewalk, and face of building.
- Further define the open space/town square next to the CVS building.
- Provide recommendations for Monroe Street West of the Monroe Street Bridge.
- Q: 'Who are the SAC/TAC members?' A: A list of invitees was handed out at the meeting.
- Provide examples of how transportation modifications and streetscape features can unify the corridor.
- Explore the option of a traffic circle at the 12th Street and Michigan Avenue intersection to improve (Northbound) and make possible (Southbound) the entrance in to 12th Street from Michigan Avenue.

Report Improvements:

- Label all streets in maps.
- Caption all images.
- Clarify the use and kind of light poles with overhead and underground utility wires in the section graphics.
- Clarify the "Theme".

Tomika Hughey, WMATA Office of Business Planning, presented an update of the 2007 Access Station Plan, stating that the Brookland Metro Station will be part of the evaluation and improvement plan. Close cooperation with the area's stakeholders, the DC Office of Planning, and DDOT will ensure that the community's concerns are addressed. Please contact Ms. Hughey for more information.

These minutes constitute our understanding of the above meeting. Please inform the author (Baker) of any discrepancies or omissions.